



Instrument Control & Data Processing for high-reliable 'New Space' instruments



Gerard.Rauwerda@technolution.nl
www.technolution.com/advance

The **Control & Data Processing Unit (CDPU)** offers flexibility and reduced Time-to-Orbit for compact SmallSat instruments

- Flexibility at design-time
- In-orbit reconfigurability
- In-orbit edge computing (image processing, encryption, instrument autonomy)
- >5 years in-orbit life-time (LEO)

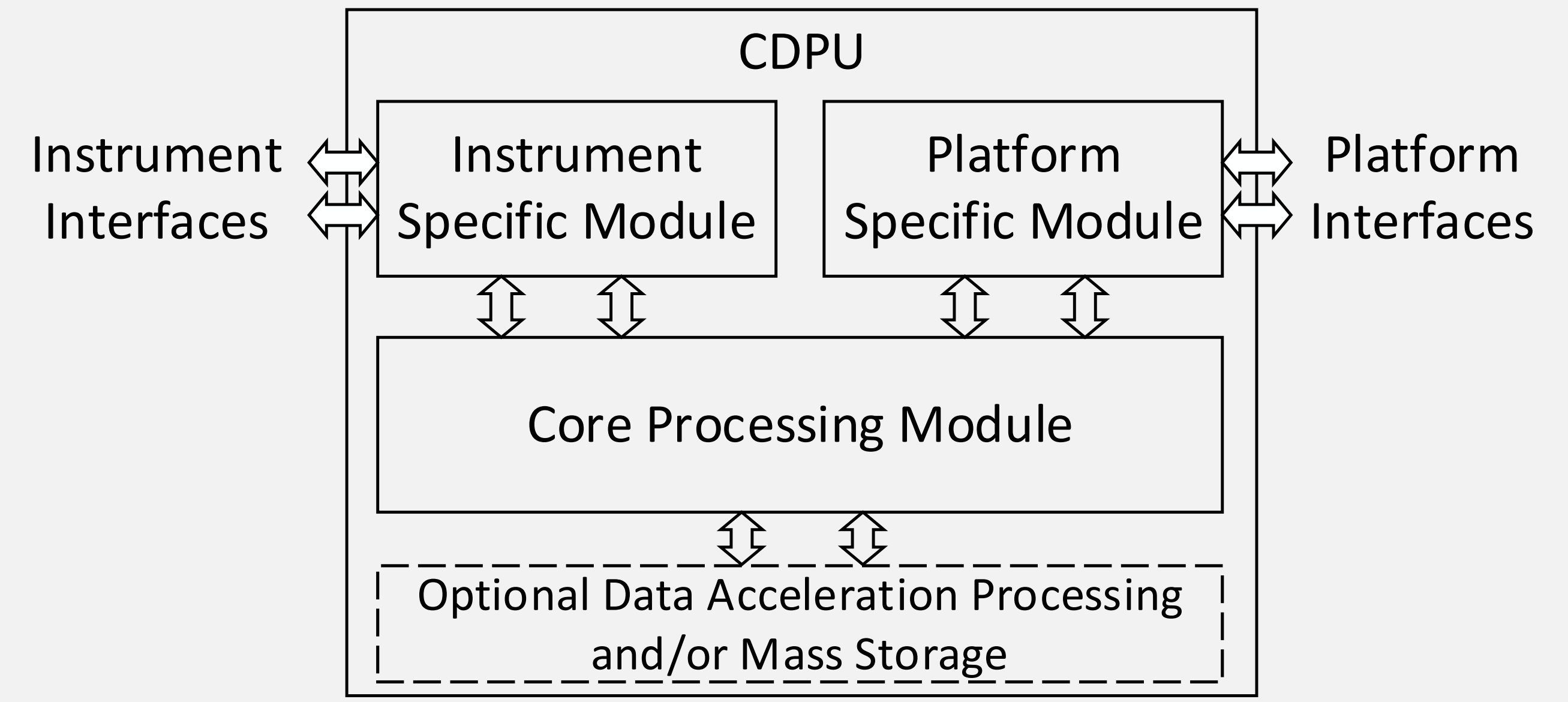

Trade-off: COTS | Rad.-tolerant | Rad.-hardened

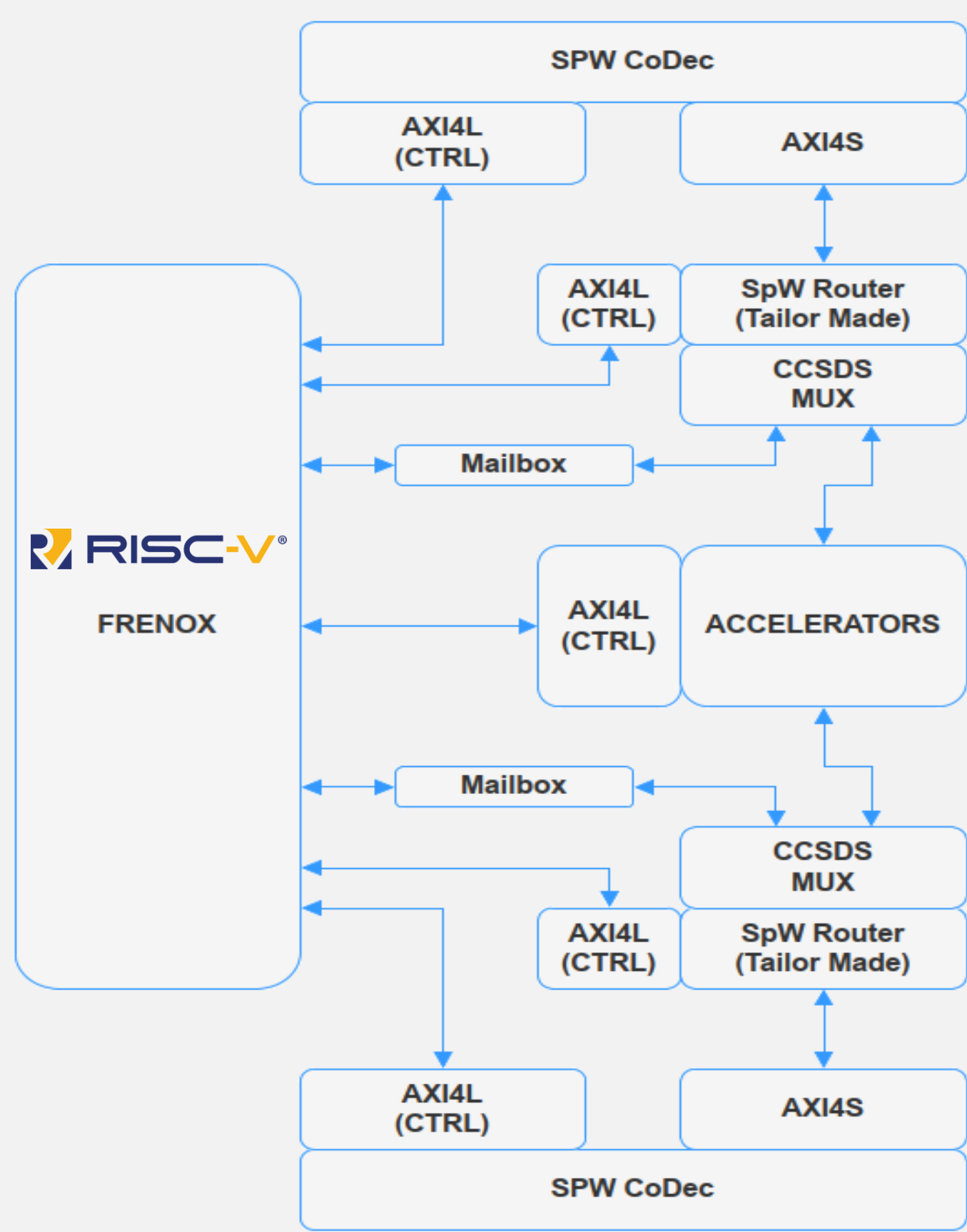

CDPU base-line design:

- **FreNox RISC-V IP (RV32IMA)**
- SpW interface IP
- SpFi interface IP
- AXI interconnect infrastructure
- Accelerator support

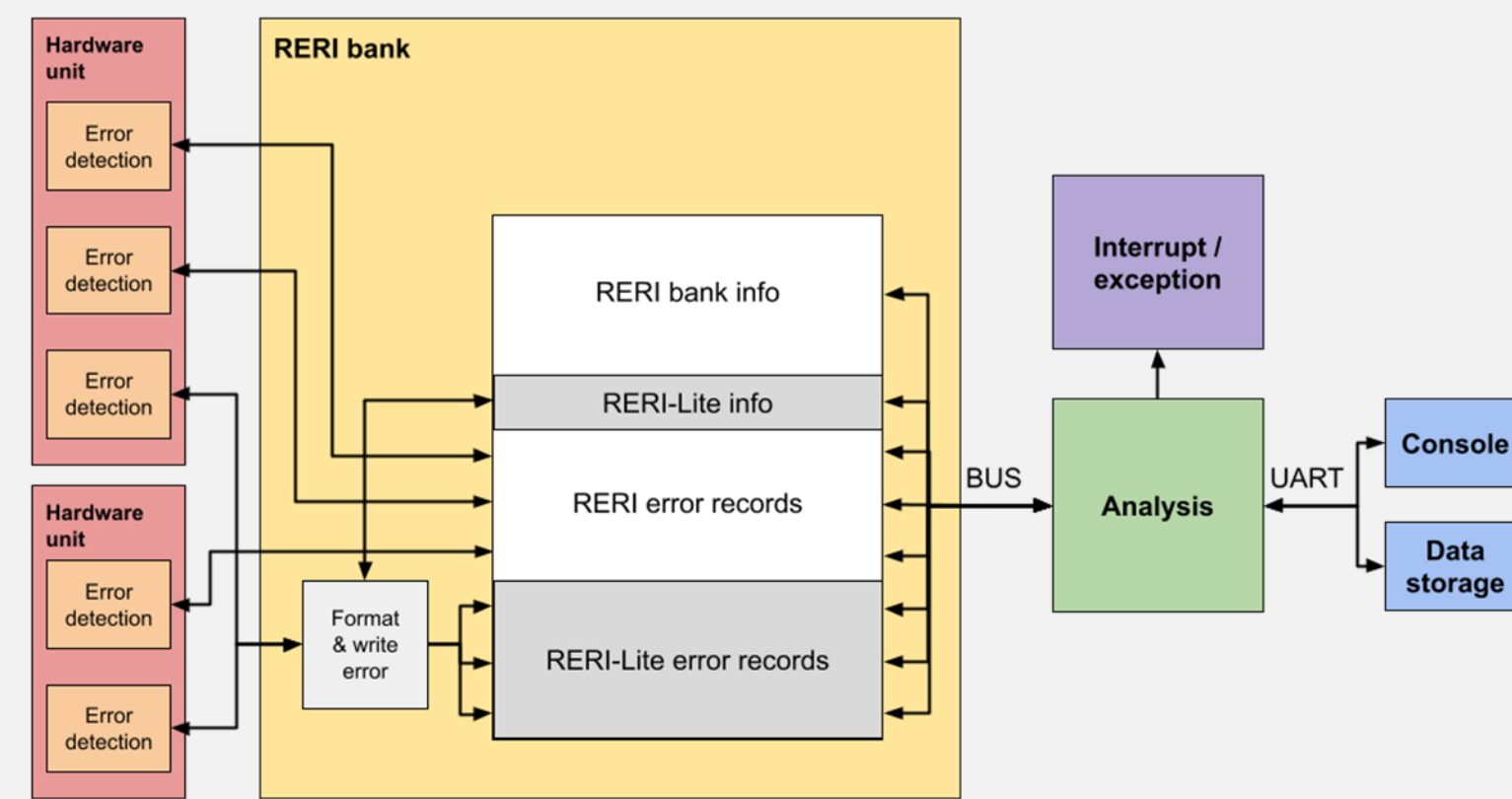

High-Reliability & High-Security features:

- Lockstep
- Error Detection and Correction
- Lightweight checkers (Hardware Trojans & SEE)
- RERI (RAS Error-record Register Interface) / FDIR handling
- PQC encryption & authentication
- Secure boot & reconfiguration



UNIVERSITY OF TWENTE



Protect. Renew. Empower.

data rate | bandwidth | latency

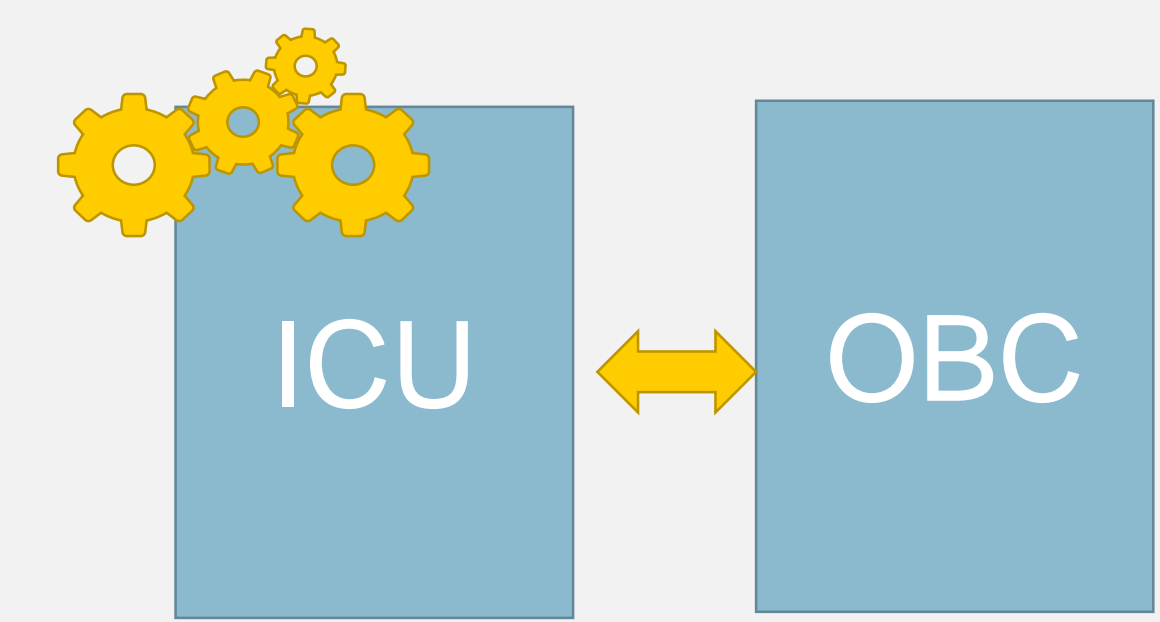
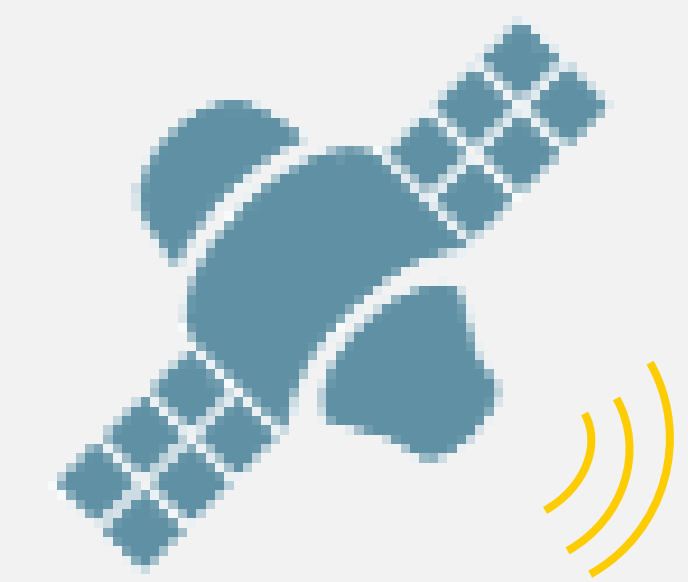

edge processing

Challenges to address for 'New Space' SmallSat

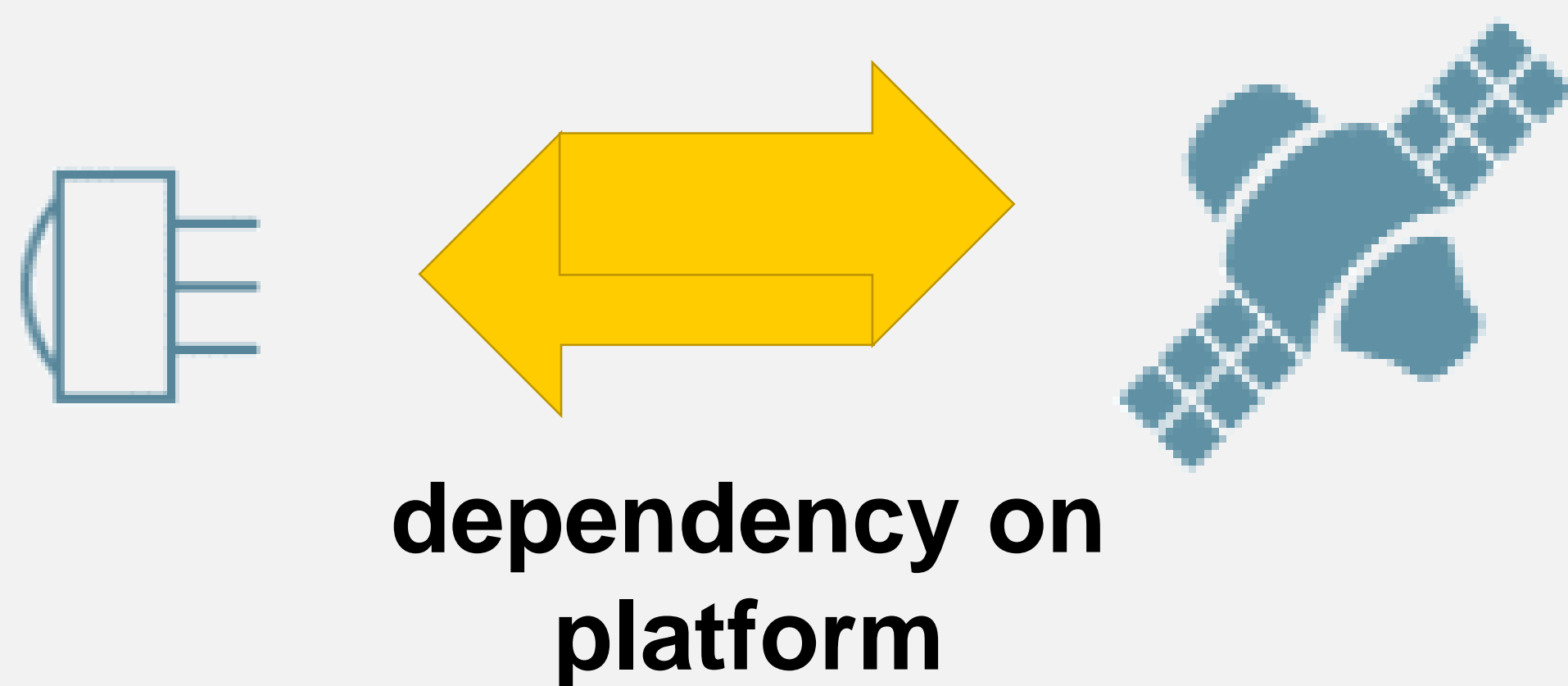

dependency on platform

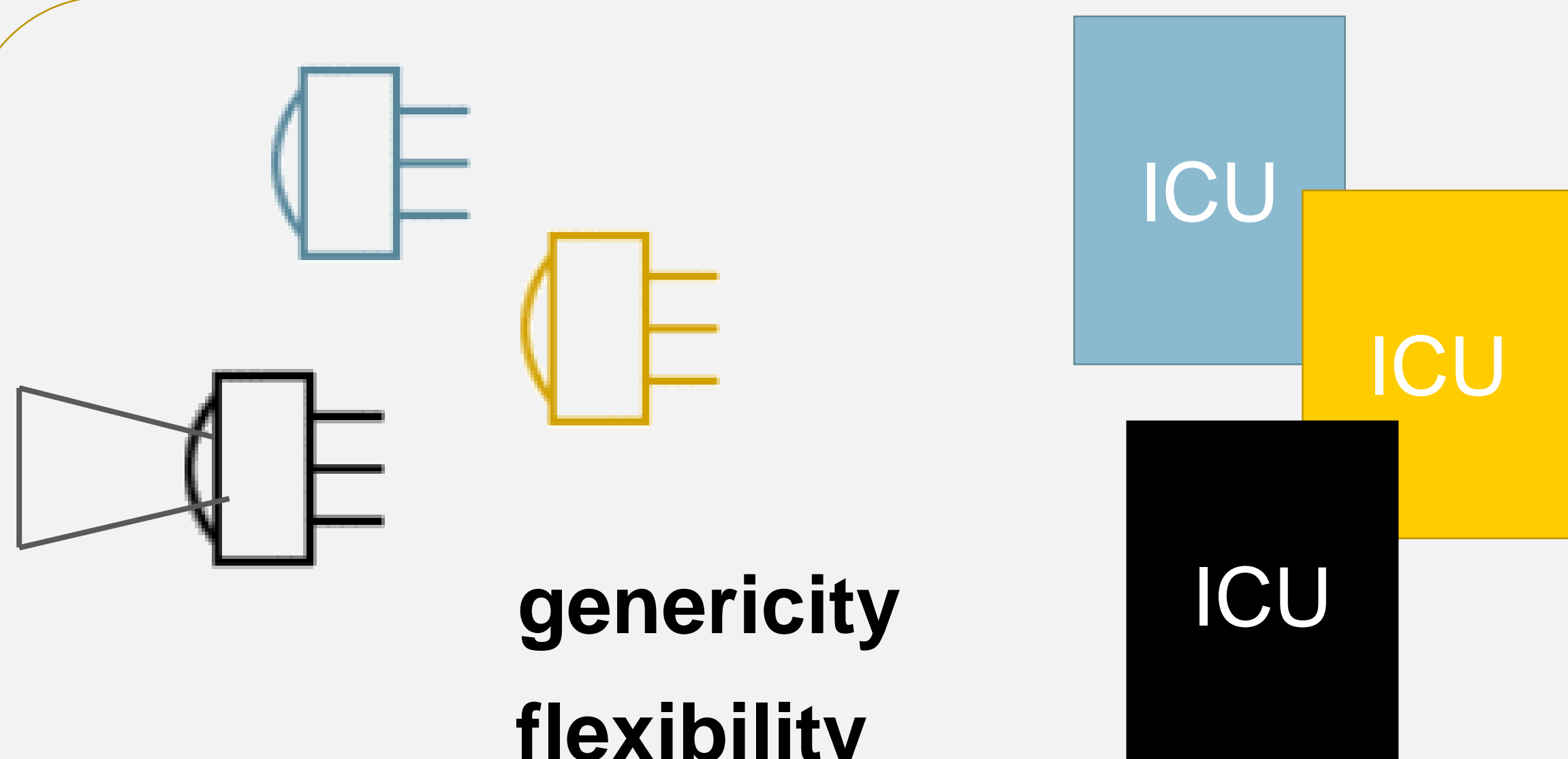

genericity flexibility

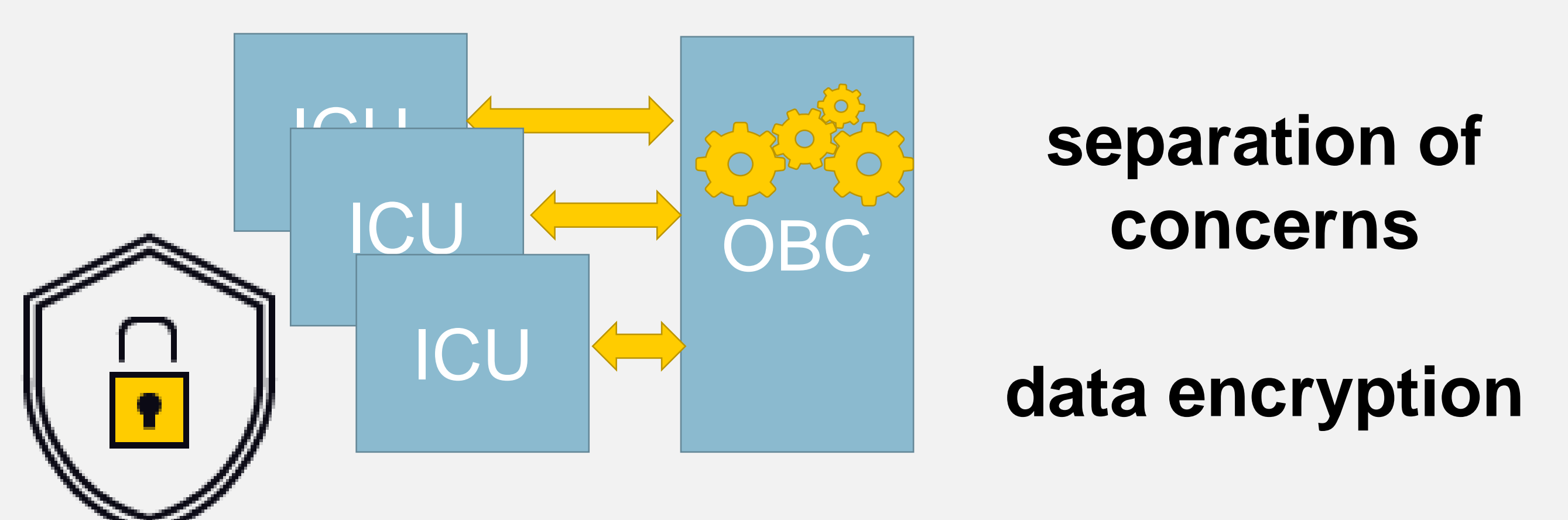

separation of concerns
data encryption



TRISTAN Project has received funding from the Chips Joint Undertaking (Chips-JU) under the grant agreement nr. 101095947. Chips-JU receives support from the European Union's Horizon Europe's research and innovation programme and Austria, Belgium, Bulgaria, Croatia, Cyprus, Czechia, Germany, Denmark, Estonia, Greece, Spain, Finland, France, Hungary, Ireland, Israel, Iceland, Italy, Lithuania, Luxembourg, Latvia, Malta, Netherlands, Norway, Poland, Portugal, Romania, Sweden, Slovenia, Slovakia and Turkey.

